

2025

LIV ASK
PRODUCTION DESIGNER

PORTFOLIO

BEFORE & AFTER

CONSTRUCTION PROCESS

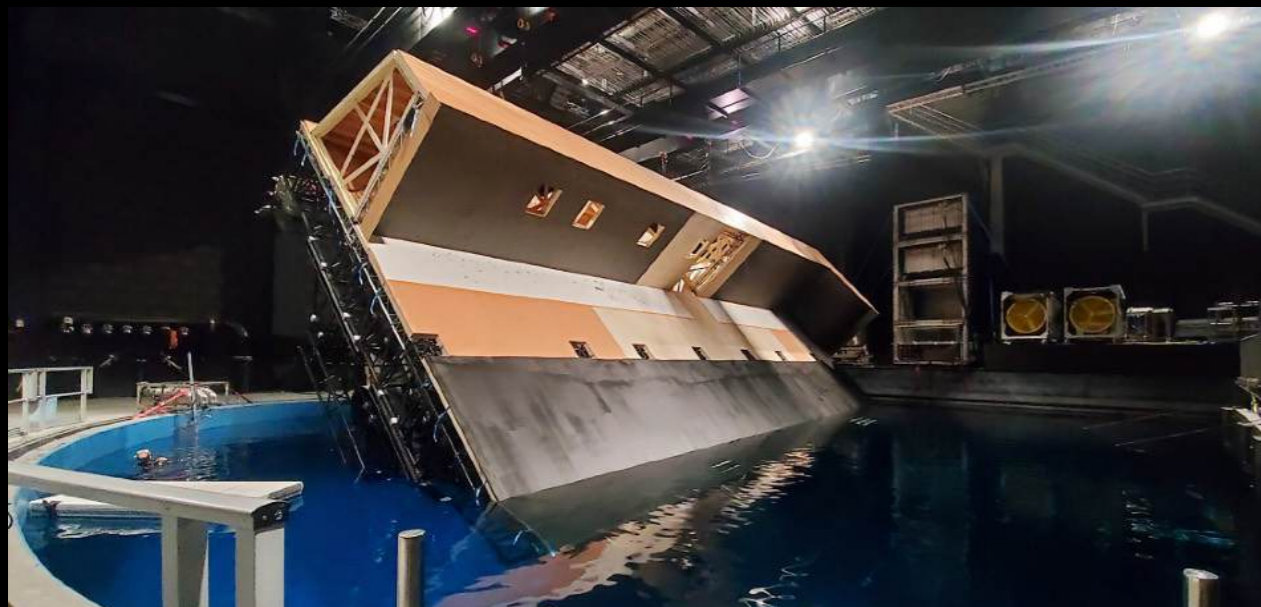

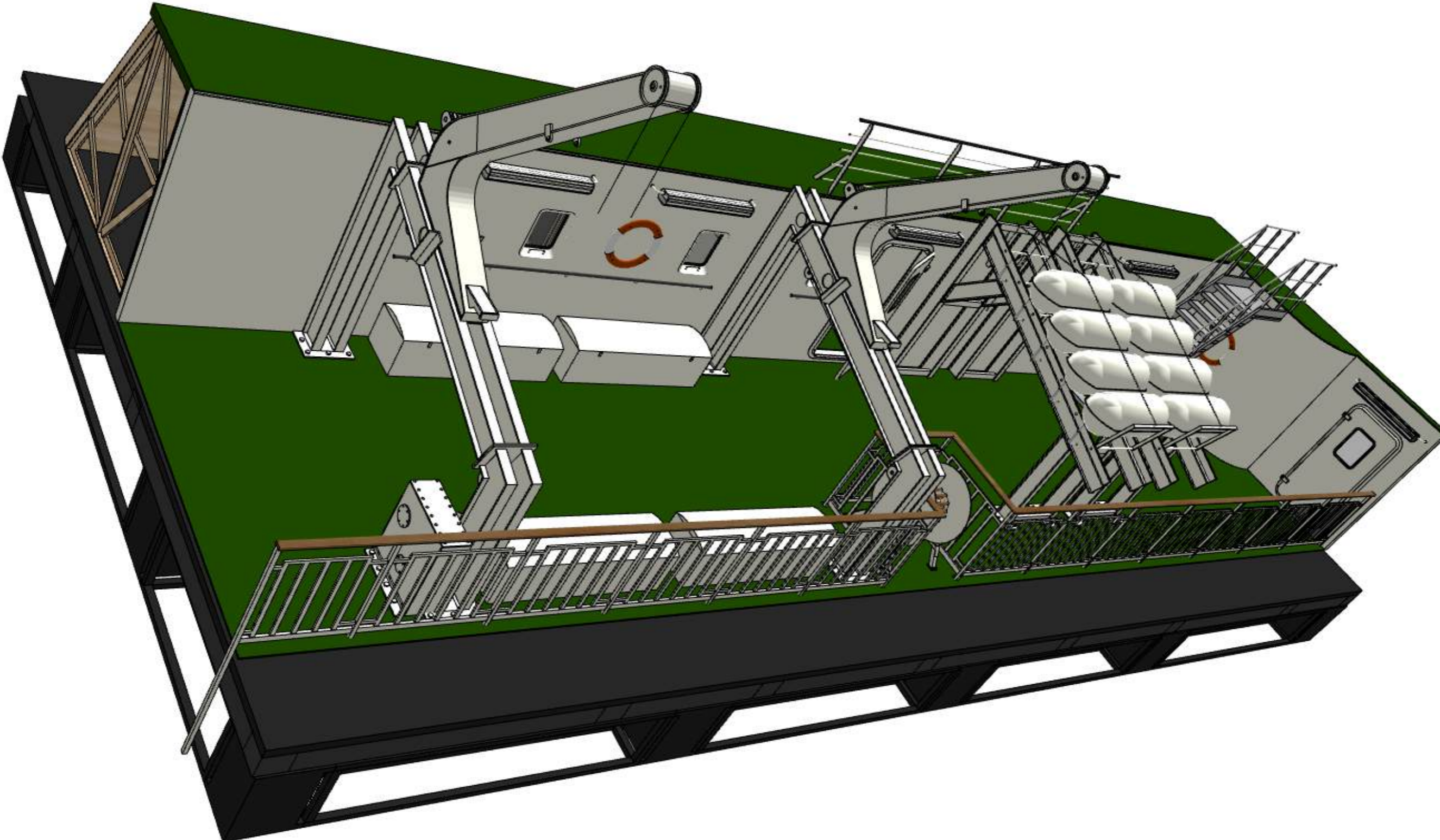



ESTONIA FRAME GRAB



ESTONIA FRAME GRAB



3D MODEL FOR SET CONSTRUCTION

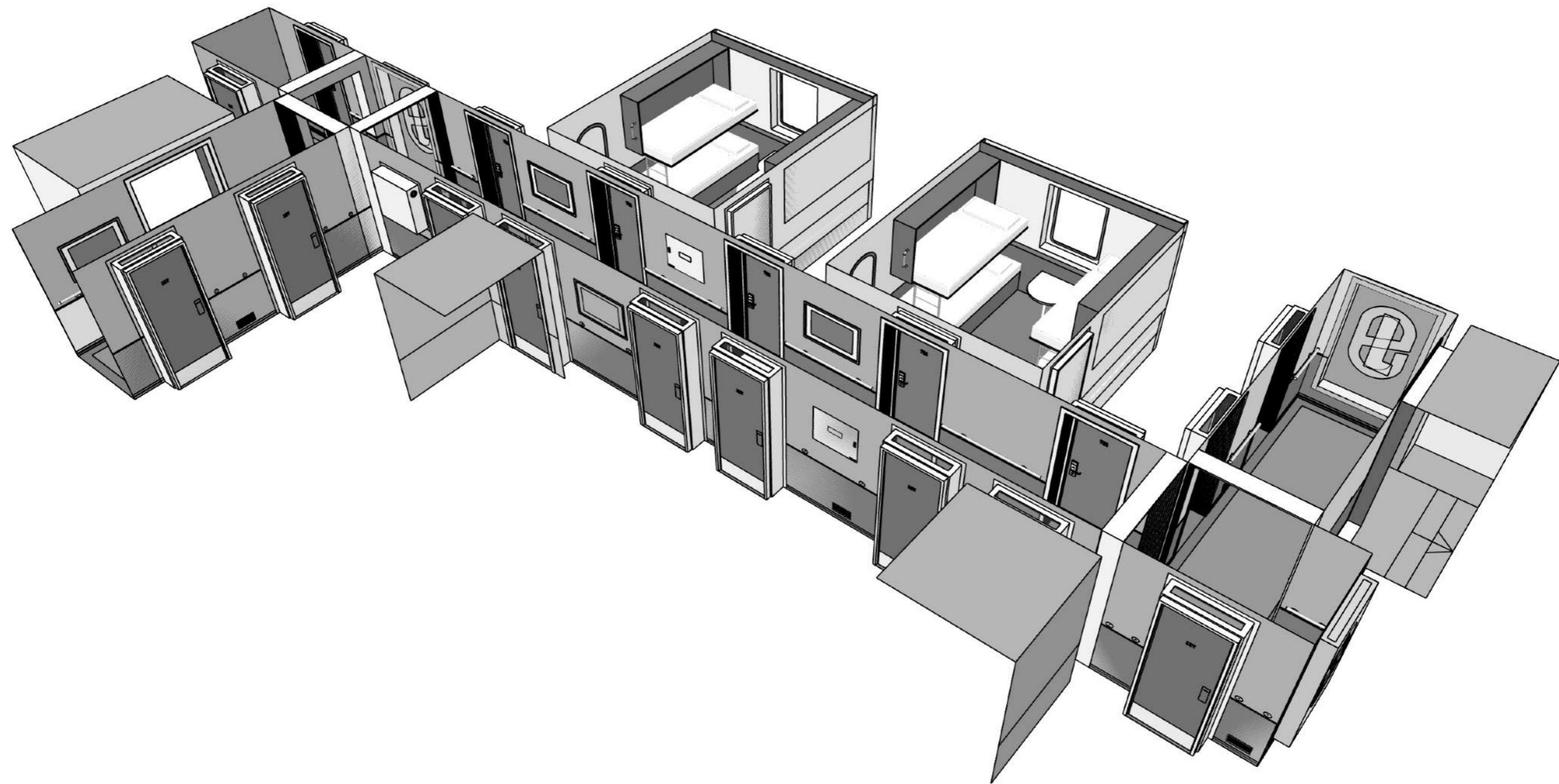

ESTONIA
2022

SET CONSTRUCTION @ LITES STUDIOS WATER TANK BELGIUM



ESTONIA
2022

ESTONIA CONCEPT DRAWING



ESTONIA SET STILL



ESTONIA FRAME GRAB



ESTONIA FRAME GRAB





SKETCH ON LOCATION PHOTOGRAPH



SET STILL OF SET CONSTRUCTION



ZIPLINE
2024
LOCATION MALTA

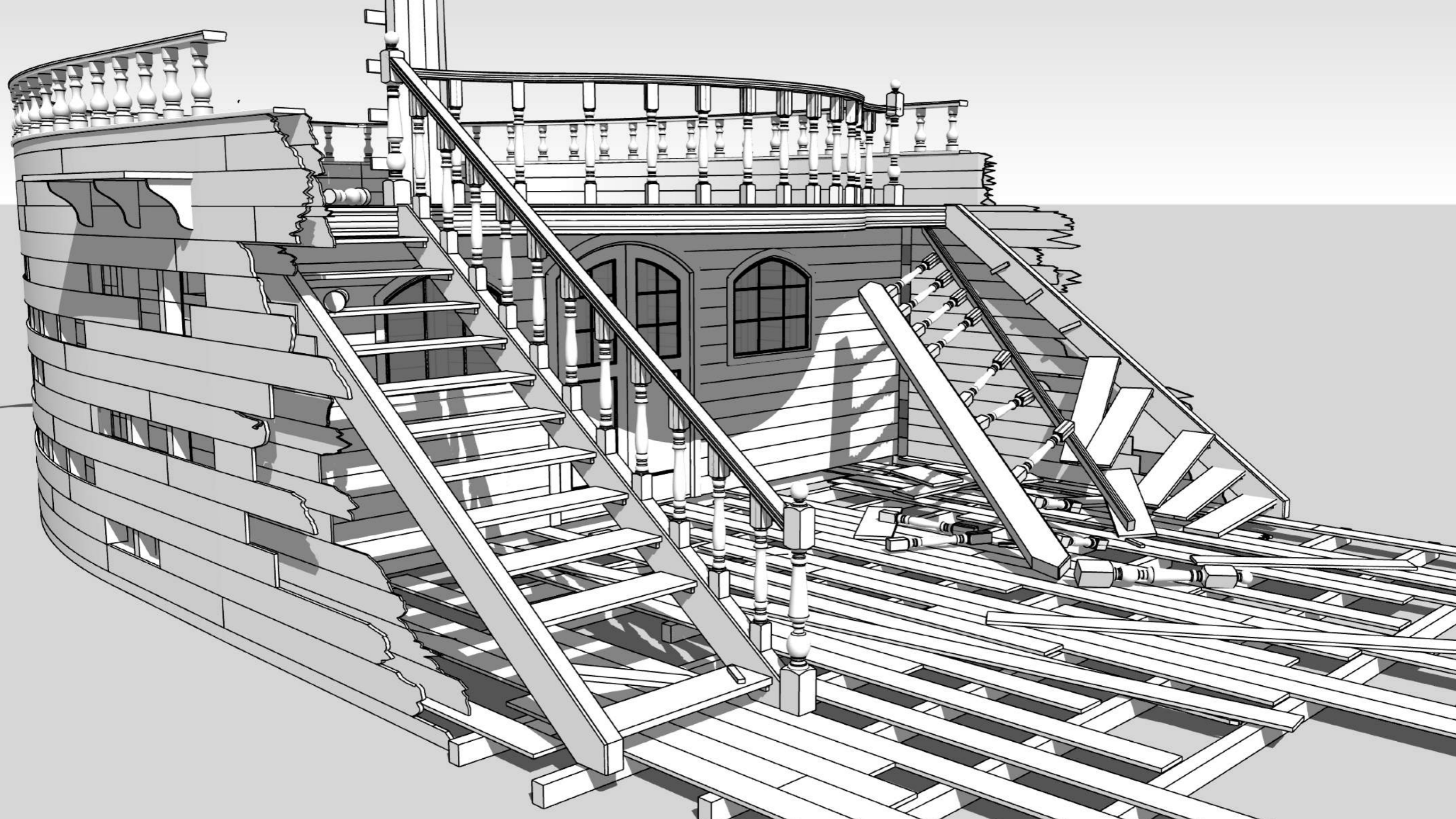

SET CONSTRUCTION ON LOCATION IN MALTA



ZIPLINE
2024

SET CONSTRUCTION ON LOCATION IN MALTA



ZIPLINE
2024

CONSTRUCTION PROCESS



3D ILLUSTRATION FOR SET BUILD IN STUDIO

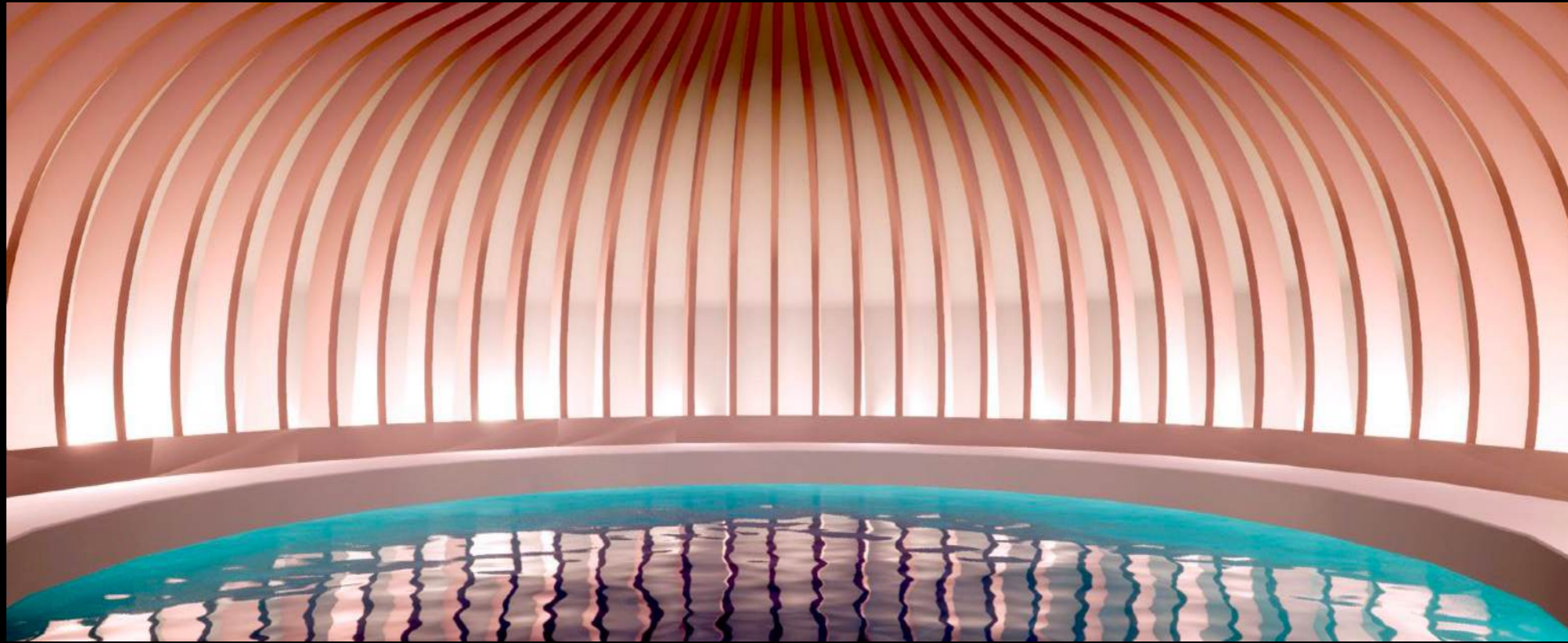

FRAME GRAB



4 HER COMMERCIAL
2023
WATER TANK FACILITIES NORWAY

SKETCH FOR SET BUILD ON LOCATION



FRAME GRAB



HIDDEN
2017
LOCATION HUNGARY

SKETCH FOR SET BUILD ON LOCATION



SET STILL OF LOCATION BUILD



MAX ANGER: WITH ONE EYE OPEN
2020
LOCATION LITHUANIA

3D ILLUSTRATION FOR SET BUILD IN STUDIO



SET STILL OF STUDIO BUILD



MAX ANGER: WITH ONE EYE OPEN
2020
STUDIO LITHUANIA

LOCATION BEFORE



LOCATION AFTER



MAX ANGER: WITH ONE EYE OPEN
2020
LOCATION LITHUANIA

LOCATION BEFORE



LOCATION AFTER



LOCATION BEFORE



LOCATION AFTER



MAX ANGER: WITH ONE EYE OPEN
2020
LOCATION LITHUANIA

LOCATION BEFORE



LOCATION AFTER



THE PLAYLIST
2021
LOCATION CROATIA

LOCATION BEFORE



LOCATION AFTER



ESTONIA
2023
LOCATION TALLINN

LOCATION BEFORE



LOCATION AFTER



ESTONIA
2023
LOCATION BRUSSELS

LOCATION BEFORE



LOCATION AFTER



THE PLAYLIST
2021
LOCATION SWEDEN

LOCATION BEFORE



LOCATION AFTER



THE PLAYLIST
2021
LOCATION SWEDEN

LOCATION BEFORE



LOCATION AFTER



MAX ANGER: WITH ONE EYE OPEN
2020
LOCATION LITHUANIA

LOCATION BEFORE



LOCATION AFTER



CONCEPT ART



PROJECT IN DEVELOPMENT
2023
CONCEPT ART



THE MAN WHO SAVED PARIS
2021
CONCEPT ART



HIDDEN
2017
CONCEPT ART



DO YOU SEE WHAT I SEE
2020
CONCEPT ART



LIVASK

PROJECT IN DEVELOPMENT
2024
CONCEPT ART



HIDDEN
2017
CONCEPT ART



MOLLER COMMERCIAL
2023
CONCEPT ART



PRIVATE PROJECT
2024
CONCEPT ART

SET CONSTRUCTION STILLS
IN STUDIO & ON LOCATION



FLYKTEN TILL FRAMTIDEN
2015
SET CONSTRUCTION @ STUDIO FARES SWEDEN



YOUFOODZ TVC
2017
SET CONSTRUCTION @ TASTY STUDIOS AUSTRALIA



THE PLAYLIST
2021
SET CONSTRUCTION ON LOCATION IN CROATIA



THE PLAYLIST
2021
SET CONSTRUCTION @ AUDEJAS STUDIO WAREHOUSE LITHUANIA



RED TERROR
2007
SET CONSTRUCTION ON LOCATION AUSTRALIA



LAKE OF DEATH
2017
SET CONSTRUCTION @ DAGSLYS STUDIOS NORWAY



THE PLAYLIST
2021
SET CONSTRUCTION @ KINO STUDIO LITHUANIA



DEAD SNOW II
2013
SET CONSTRUCTION @ STUDIO WAREHOUSE ICELAND



FLYKTEN TILL FRAMTIDEN
2015
SET CONSTRUCTION @ STUDIO FARES SWEDEN



MAX ANGER: WITH ONE EYE OPEN
2020
SET CONSTRUCTION ON LOCATION IN LITHUANIA

TECHNICAL DRAWINGS & 3D MODELS

LAKE of DEATH - STAIRCASE CONSTRUCTION @ 1:50 on A3

GROUND FLOOR HALL

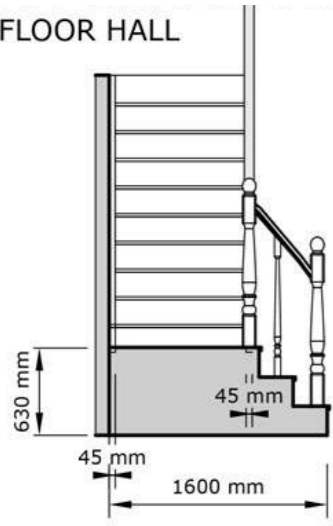

LEFT SECTION

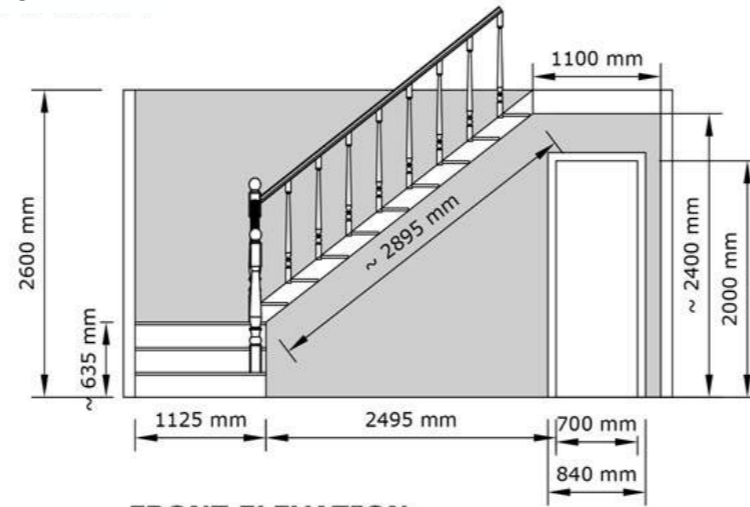

FRONT ELEVATION

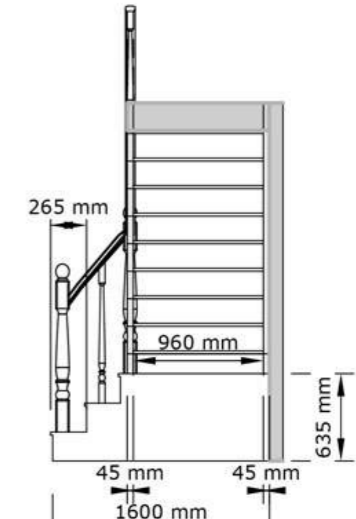

RIGHT SECTION

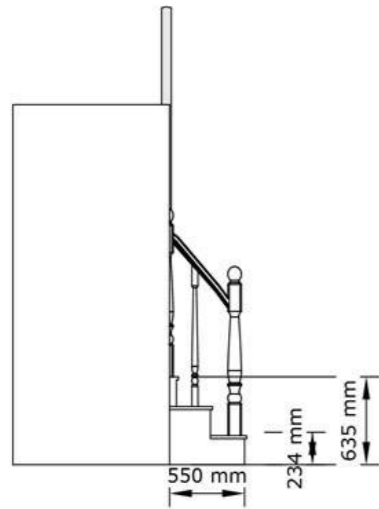

LEFT ELEVATION

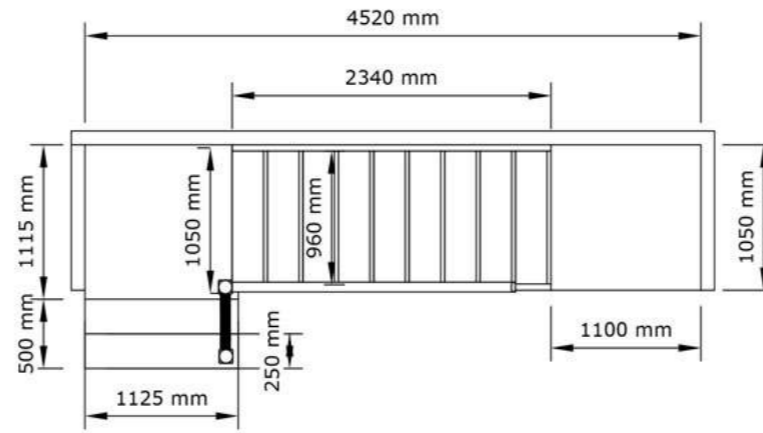

PLAN VIEW

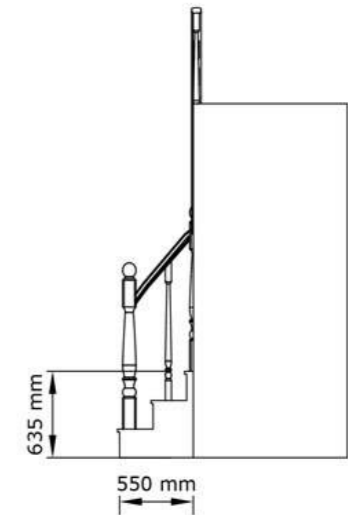

RIGHT ELEVATION

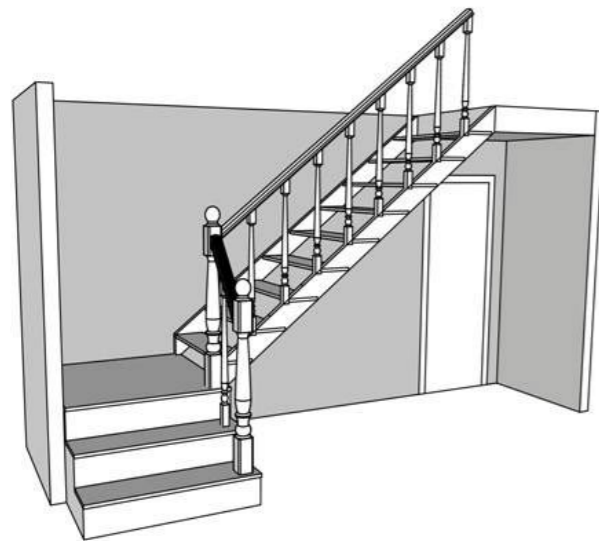

PERSPECTIVE

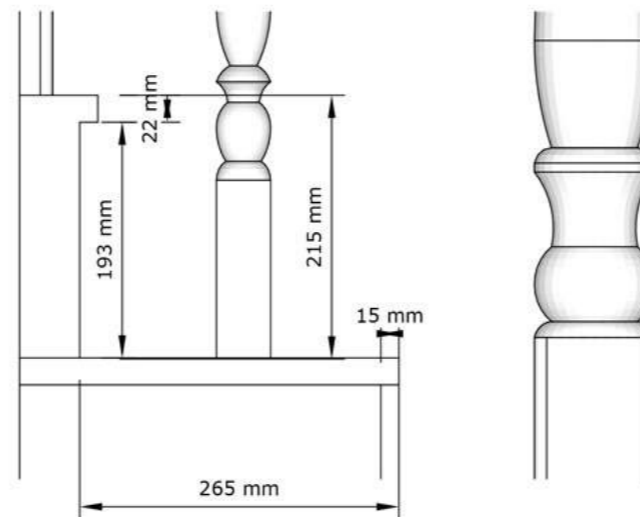

DETAIL I

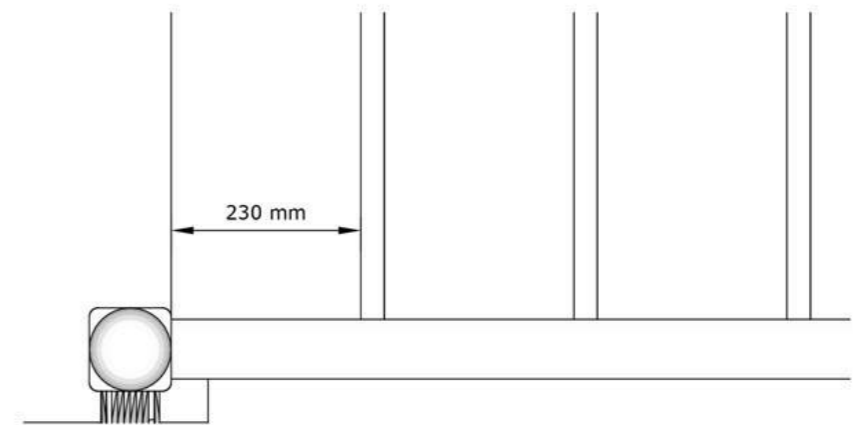

DETAIL II

V.02 01.07.18
SCALE 1:50 on A3
LIV ASK

THE SNOWMAN - HOLMENKOLLEN HOTEL - STOPS BATHROOM - PLAN & ELEVATIONS @ SCALE 1:20

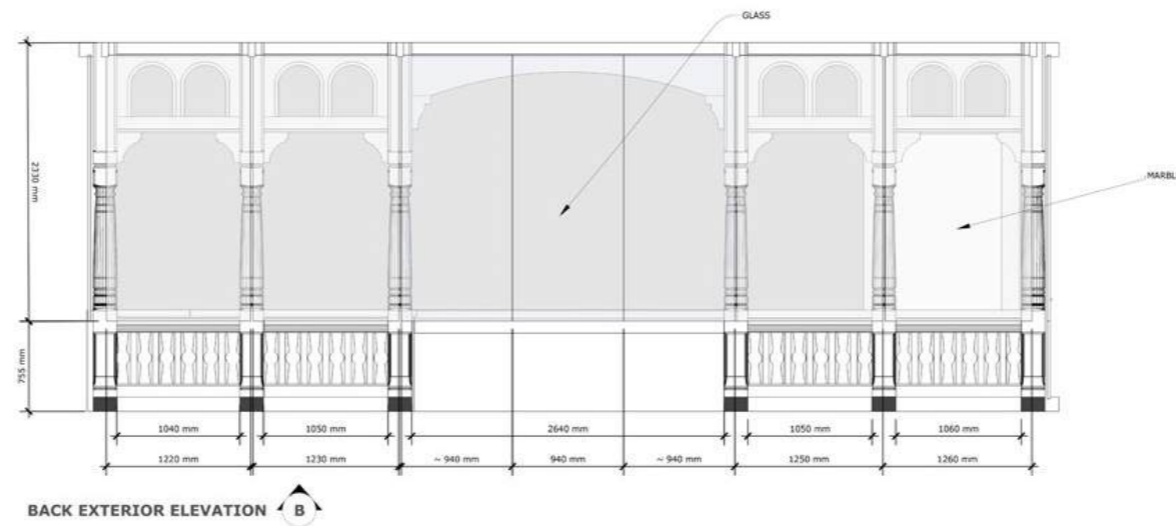
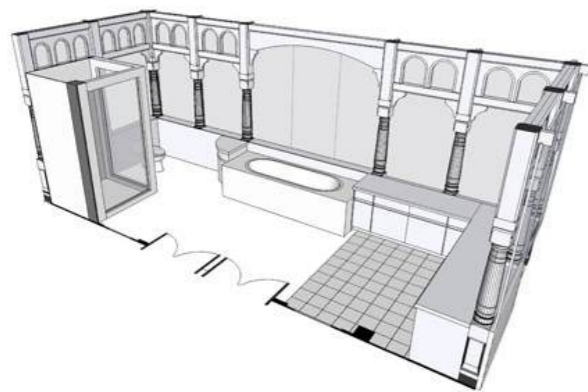
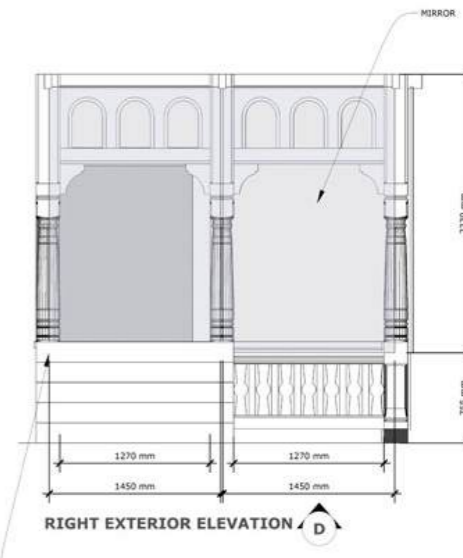
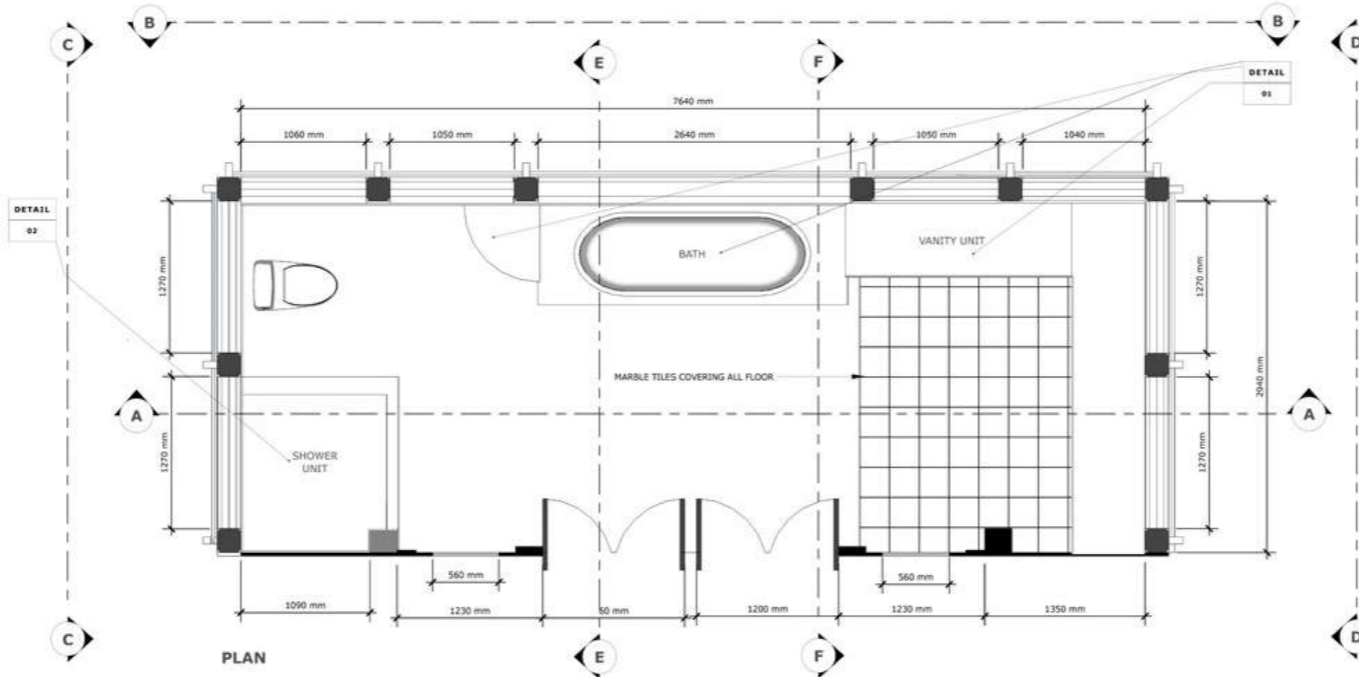
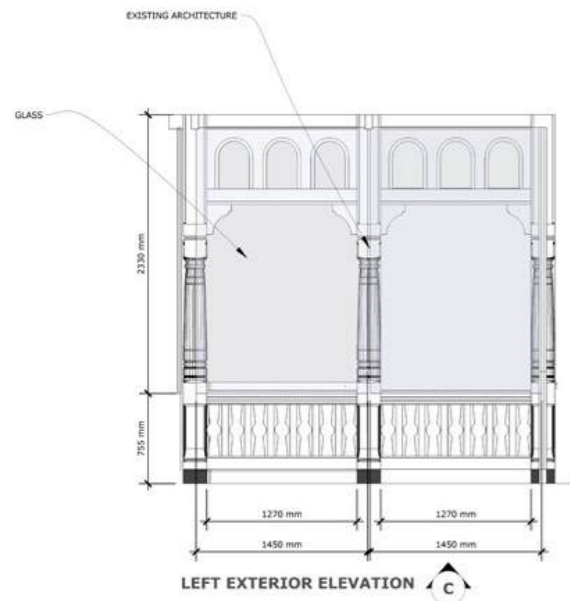
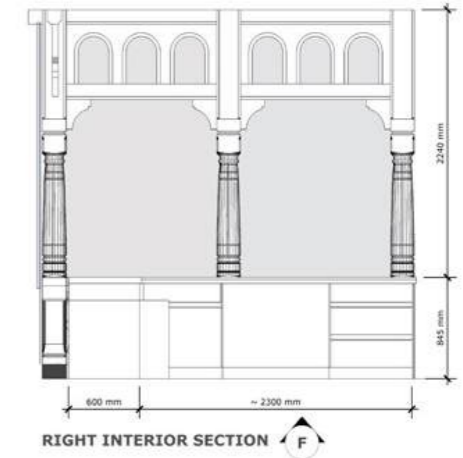
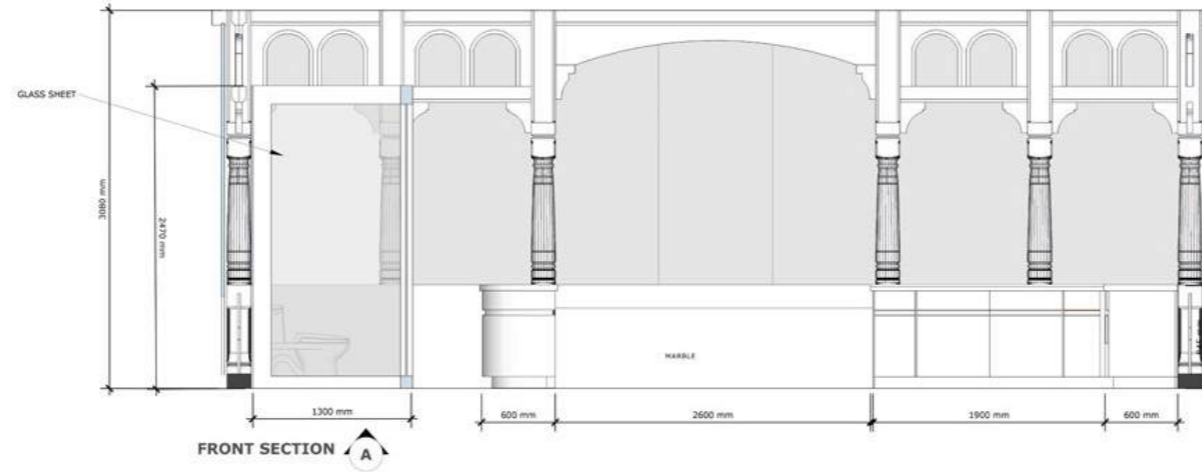
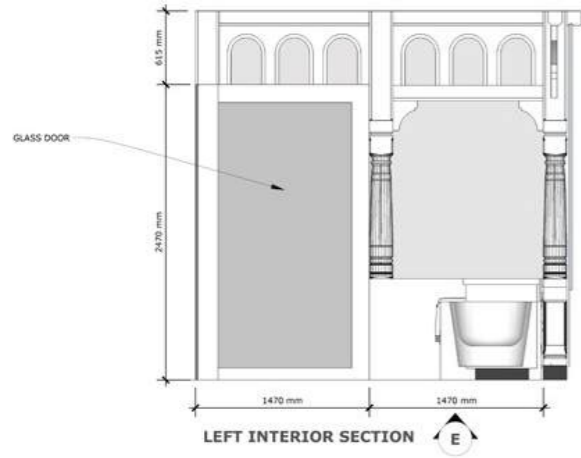

THE SNOWMAN		SET NO.	DWG. NO.
DRAPSMANN FILMS LTD.		218	01
SET: STOPS BATHROOM	LOCATION / STAGE:	HOLMENKOLLEN HOTEL	
DETAILS:		SCALE:	1:20
DATE DRAWN: NOV 17 2015	DRAWN BY: LIV ASK	DATE ISSUED: 17 DEC	REVISED:
PRODUCTION DESIGNER: MARIA DJURKOVIC			
DIRECTOR:	ART DEPT:	CON. MANAGER:	RIGGERS:
PRODUCTION:	SET DECOR:	CARPENTERS:	SFX:
D.O.P.:	PROPS:	PLASTERERS:	VFX:
ASST. DIRECTORS:	PROP MAKING:	PAINTERS:	COMPUTER / VID:
STUNTS:	SIGN WRITER:	SCULPTORS:	COSTUMES:
GAFFER:	GRAPHICS:	METAL WORK:	
PRAC. ELEC.:	GREENERY:	SCENIC ART:	
HEALTH & SAFETY:	LOCATIONS:	DRAPES:	APPROVED:

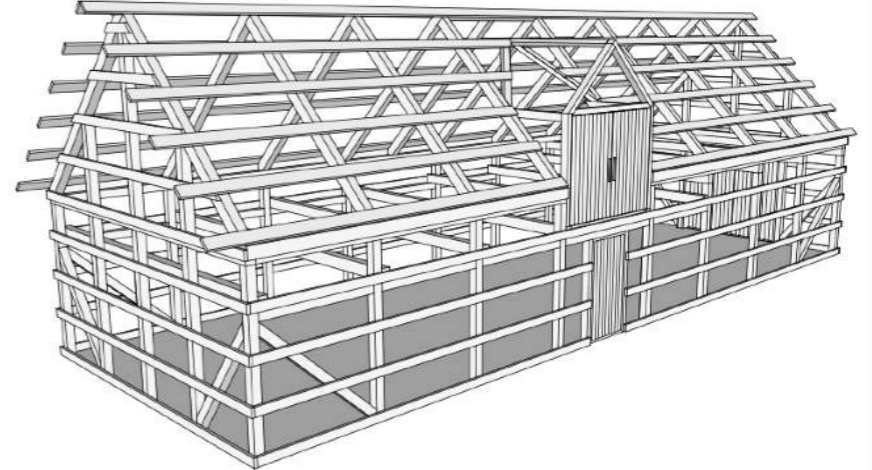
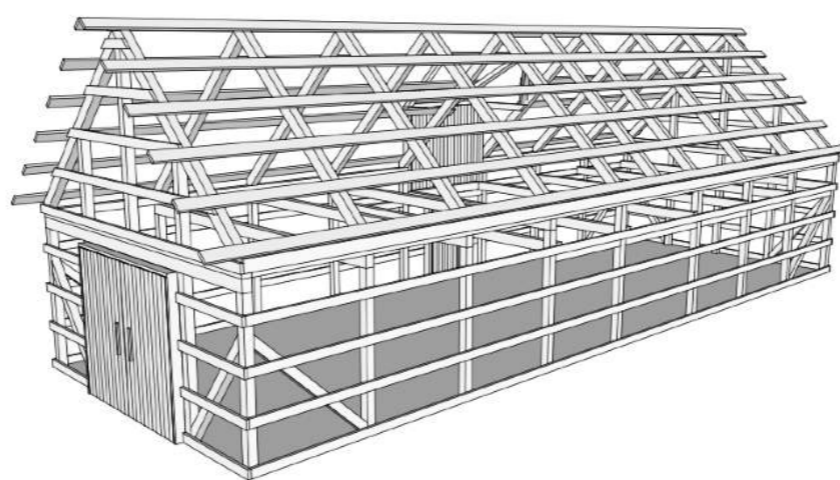
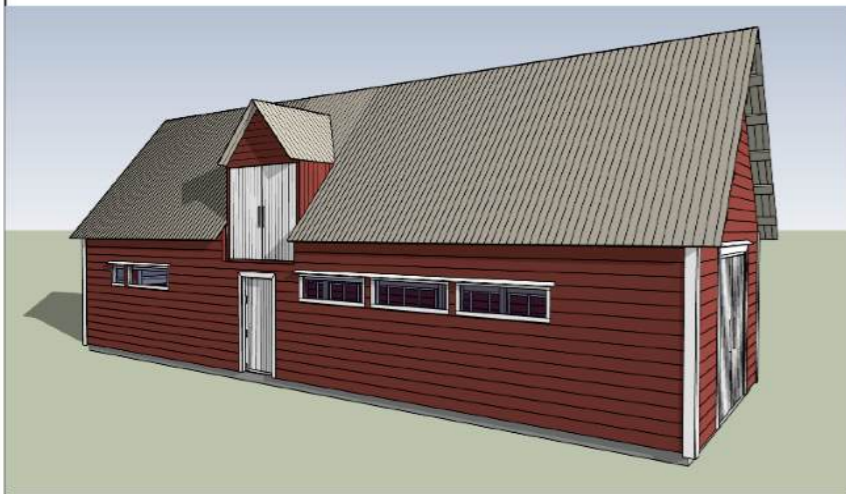
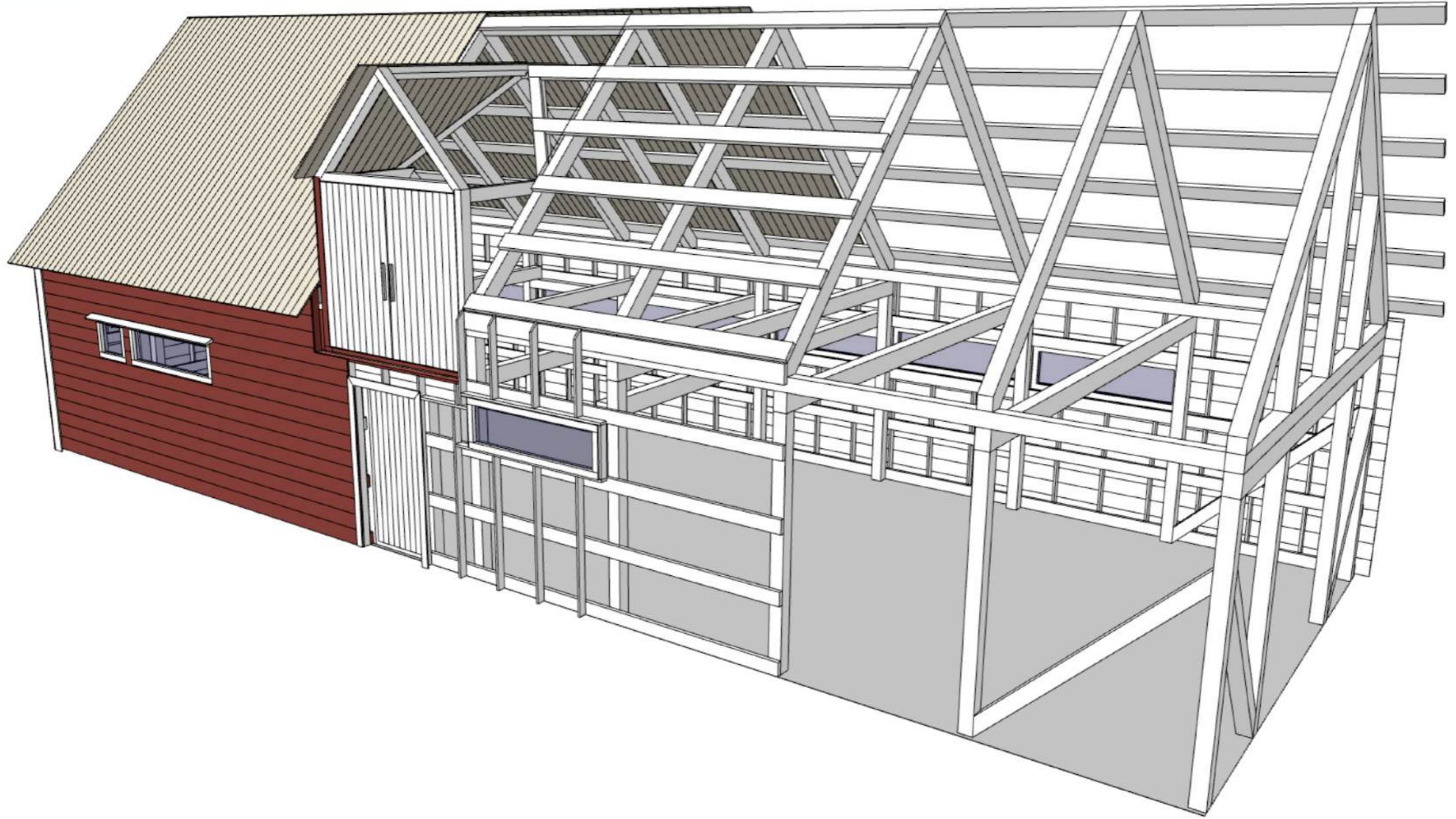

DRAWN BY LIV ASK 17.12.24

THE MØKSTER BARN
2024
TECHNICAL DRAWING FOR PERMANENT CONSTRUCTION

THE OLD HOUSE

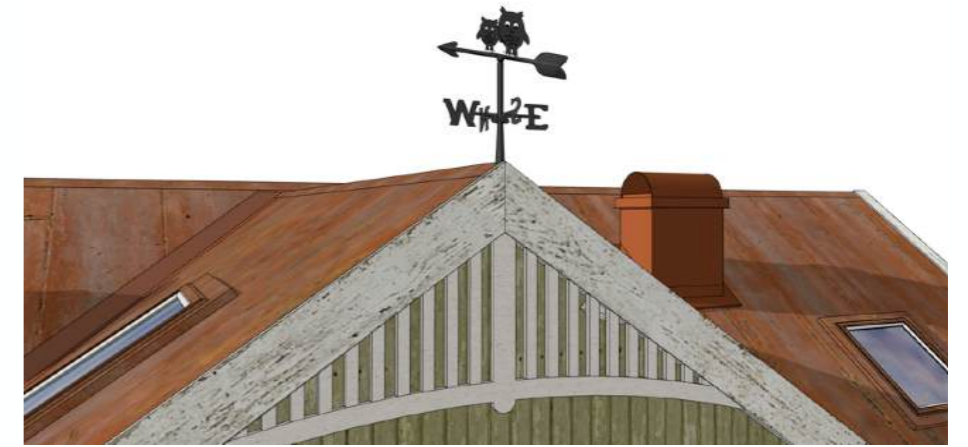

SET: EXT. THE OLD HOUSE

PROJECT: A MOUSE HUNT FOR CHRISTMAS

DATE: MAY 2024

LOC: STUDIO BACKLOT T.B.D

SCALE: N/A

PRODUCTION COMPANY: FANTEFILM

DRAWN BY: LIV ASK

THANK YOU

CONTACT

Email: livask@gmail.com

Website: livask.com

Instagram: [iamlivask](https://www.instagram.com/iamlivask)

Represented by
THE TALENT GROUP AGENCY
<http://www.thetalentgroup.eu/>